

Project		Date
Type		
Model		

CHB2 Series LED High Bay

Features

- Magnesium alloy housing maximizes cooling.
- Tempered glass lens.
- UL 94 Flame Rating - 5VA rating on housing.
- Available in 90W to 320W options.
- Light engines are available in 4000K and 5000K configurations.
- Lumen output from 13,500 - 48,000lm
- Efficacy up to 150lm/W.
- 120-277VAC / 50/60Hz.
- Operating temperature is -40°F to 113°F
- 0-10v dimming, 10%-100%



Adjustable

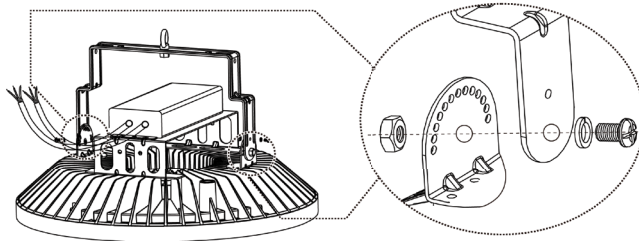

ORDER INFORMATION

EXAMPLE: CHB2-140W-40K-Y-SV-CL



Series	Wattage	CCT	Voltage	Finish	Lens	CRI
CHB2	90W	40K = 4000K	Y = 120-277V	SV = Silver	CL = Clear FR = Frosted	Blank = 80CRI Standard CRI90 = 90 CRI**
	140W	50K = 5000K	HV = 347-480V**			
	180W					
	240W					
	320W					

Enter configuration:

** Special Order

PERFORMANCE DATA

Model	CHB2-90W	CHB2-140W	CHB2-180W	CHB2-240W	CHB2-320W
System Power	90W	140W	180W	240W	320W
Voltage	120-277VAC				
Frequency	50/60Hz				
Lumen output (Max)	13,500lm	21,000lm	27,000lm	36,000lm	48,000lm
Efficacy	150 lm/W				
Diffuser	Tempered glass				
Body materials	Magnesium Alloy				
Finish	Silver				
LED type	3030				
CCT	4000K / 5000K				
CRI	80 (90 optional)				
PF	>0.9				
Beam angel	120°				
IP	IP65				
IK	IK08				
Installation	Suspension				
Operating Temp.	-40°F to 113°F				
Certificate	UL / DLC Premium				
Product size	∅ 12.99 x 5.51in	∅ 12.99 x 5.51in	∅ 16.92 x 6.49in	∅ 16.92 x 6.49in	∅ 16.92 x 6.49in
Carton size	14.7 x 14.7 x 6.88in	14.7 x 14.7 x 6.88in	18.7 x 18.7 x 6.88in	18.7 x 18.7 x 6.88in	18.7 x 18.7 x 6.88in
Qty / CTN	1pcs	1pcs	1pcs	1pcs	1pcs

DIMENSIONS

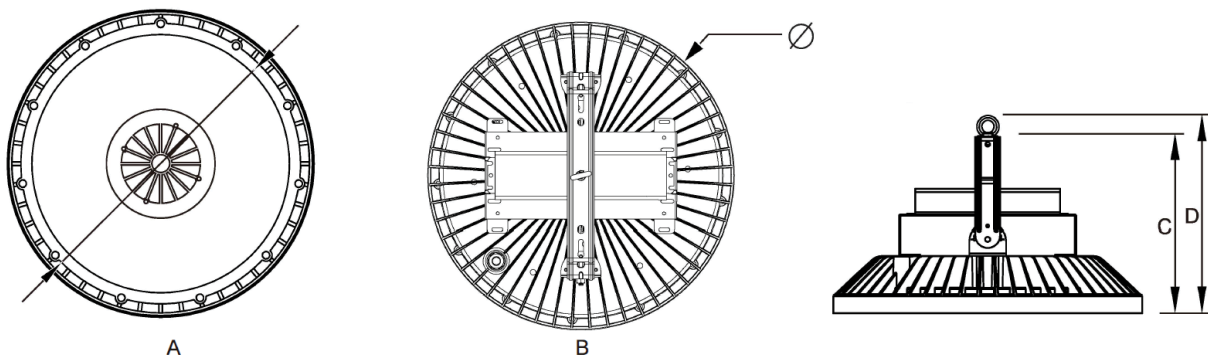

Model	CHB2-90W	CHB2-140W	CHB2-180W	CHB2-240W	CHB2-320W
A	10.9 in	10.9 in	14.8 in	14.8 in	14.8 in
B	12.9 in	12.9 in	16.9 in	16.9 in	16.9 in
C	8.66 in	8.66 in	9.84 in	9.84 in	9.84 in
D	9.92 in	9.92 in	11.02 in	11.02 in	11.02 in