

## ▼ IMPORTANT SAFEGUARDS

1. To prevent high voltage from being present on the purple and blue output leads prior to installation. The LED emergency driver connector must be open. Join the unit connector after it has been installed and before the AC power is supplied.
2. Make sure all connections are in accordance with the National Electrical Code or any local regulations.
3. To reduce the risk of electric shock, disconnect both normal and auxiliary power supplies and unit connector of the LED emergency driver before servicing.
4. An AC power source (100-277VAC, 50/60Hz) ahead of any wall switch is required to provide battery charging current.
5. Do not install near gas or electric heaters.
6. This product is for use with indoor or damp locations where ambient temperature is (0°C to 50°C). It is not suitable for wet. Do not use in heated air outlets, hazardous locations and outdoor.
7. For use with grounded, UL Listed, damp location rated, indoor fixtures and case should be grounding.
8. The LED emergency drivers are intended for ordinary locations and for permanent installation into one or more emergency luminaires.
9. This LED emergency driver has not been investigated for use in an air handling fixture.
10. This is a sealed unit. Integral battery is not replaceable. Replace entire unit when necessary.
11. The use of accessory equipment not recommended by the manufacturer may cause an unsafe condition.
12. Servicing should be performed by qualified service personnel.
13. LED emergency driver should be mounted in locations and at heights where it will not be subjected to tampering by unauthorized personnel. Indicator light should be mounted can see location.
14. LED emergency driver is only use for LED lighting emergency backup. Do not use it for other than its intended use.
15. The weight of the LED emergency driver should be considered before installation.
16. CAUTION - This emergency battery pack for use LED lamp or LED fixture. Suitable voltage of LED fixture is AC100-120V.

## SAVE THESE INSTRUCTIONS



This product contains a rechargeable LiFePo4 battery.  
**THE BATTERY MUST BE RECYCLED OR DISPOSED OF PROPERLY TO PREVENT FIRE.**



**CAUTION: Before installing, make certain the A. C. power is off and the LED lamp emergency backup unit connector is disconnected.**

NOTE : Make sure that the necessary branch circuit wiring is available. An unswitched source of power is required. The unswitched and switched power source must be fed from the same branch circuit.

## OPERATION

During normal operation, AC power is supplied to the AC driver through the LED emergency driver and charged the battery. The AC input line voltage (100-277V AC) of LED emergency driver automatically sets the output voltage during emergency mode.

When AC power fails, the LED emergency driver automatically switches to emergency mode, keeping the load illuminated for a minimum of 90 minutes. When AC power is restored, the LED emergency driver returns to charging mode. The LED emergency driver consists of a low-battery voltage disconnect which is reset when AC power is restored.

## INSTALLING THE EMERGENCY DRIVER

- The LED emergency driver will be located between the AC power sources and the AC driver.
- The LED emergency driver may be installed in close proximity to the fixture or remote from the fixture.
- The maximum remote distance using 16AWG wire is 15ft. Contact the factory for more information.
- The AC power is fed to the LED emergency driver.
- The AC driver receives power from the LED emergency driver. Identify the output wires of the LED emergency driver by the presence of the orange and blue leads.

## MOUNTING

- Method 1: Mount the LED emergency driver outside the LED luminaire with flexible conduct.
- Method 2: Mount the LED emergency driver inside the LED luminaire without flexible conduct.
- Method 3: Optional T-grid mounting kit

The T-grid mounting kit is safer to mount the LED emergency driver on the T-grid ceiling. It is sold separately and is available from the factory as an accessory kit. Call your local distributor or the factory for complete information.

- ① - Flexible conduit (supplied) to connect AC driver wires.
- ② - Existing conduit to run existing wires to lamp holder.
- ③ - AC line in.
- ④ - Conduit and junction box (not supplied).

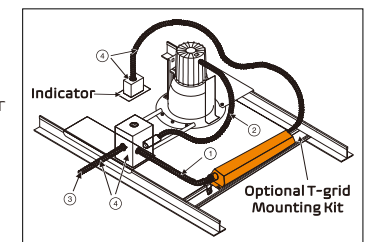

## WIRING THE EMERGENCY DRIVER

Select the appropriate wiring diagram to connect the emergency driver to the AC driver and LED load.

Table A

Item	Rated Power	
	NO wiring the 0-10V dimming wires	Wiring the 0-10V dimming wires
16W Version	≤18w	Max160w fixture can dimming to ≤16w
25W Version	≤25w	Max200w fixture can dimming to ≤25w

### 1. Wiring : If Power Of Luminaire > Power Of LED Emergency Driver.

Ensure the LED load's rated power is greater than the power output of this emergency LED driver

- 16W: Compatible up to 160w LED luminaire when wiring 0-10V dimming wires
- 25W: Compatible up to 200w LED luminaire when wiring 0-10V dimming wires
- Minimum dim-down power of LED luminaire ≤ the power output of this emergency LED driver.
- It must connect 0-10V dimming wires if Power Of Luminaire > Power Of LED Emergency Driver.

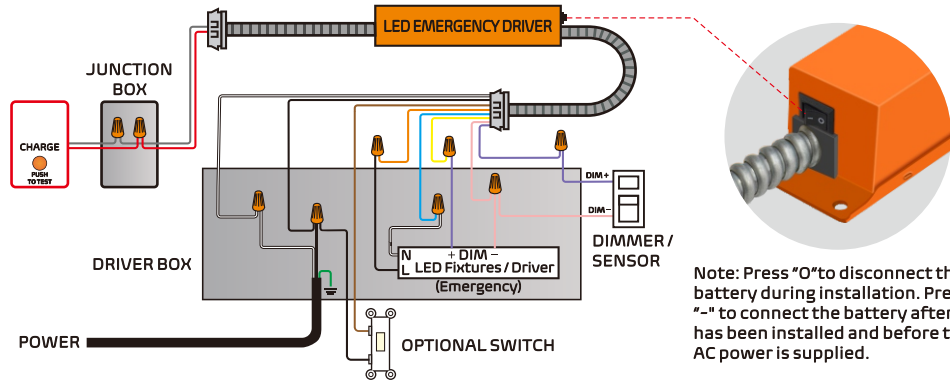

### 2. Wiring : If Power Of Luminaire ≤ Power Of LED Emergency Driver.

Ensure the LED load's rated power is less than or equal to the power output of this emergency LED driver

- 16W: Compatible up to 18w LED luminaire when NO wiring 0-10V dimming wires
- 25W: Compatible up to 25w LED luminaire when NO wiring 0-10V dimming wires
- No need to connect 0-10V dimming wires

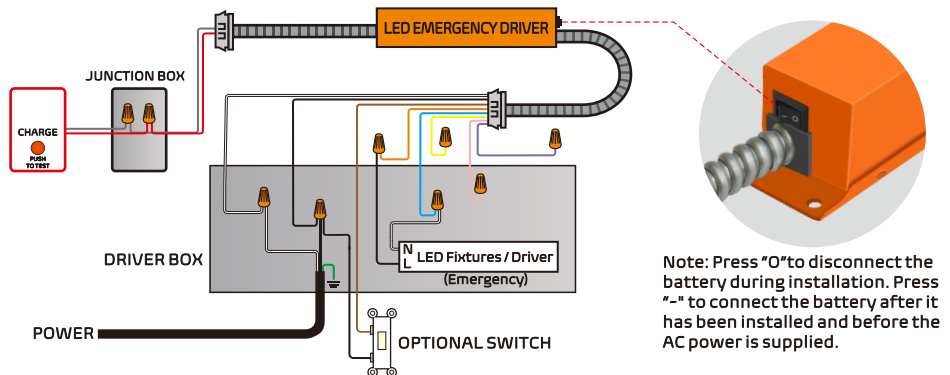

## TESTING OPERATION

Automatic Detection Modes	
Power-On Self-Test	Trigger: Upon power connection
	Duration: Max. 2 minutes
Monthly Auto-Test	Trigger: Day 30 (after light OFF + 6-hour delay)
	Duration: 35 seconds
Semi-Annual Auto-Test	Trigger: Day 180 (after light OFF + 6-hour delay)
	Duration: 30 minutes
Annual Auto-Test	Trigger: Day 365 (after light OFF + 6-hour delay)
	Duration: 90 minutes

Manual Button Test Operations
Single Press (1x) Action: Initiates 35-second self-test
Double Press (2x) Action: Initiates 30-minute self-test
Triple Press (3x) Action: Initiates 90-minute self-test
Long Press for 3 seconds Action: Cancels ongoing self-test
Long Press for 10 seconds Action: Forces system reset & reboot

### Key Notes:

All time-based tests initiate 6 hours after the fixture is turned OFF; Test cycles are calculated from the last power-on date "Day 30/180/365" refers to cumulative operational days

### Safety Notice:

» Interrupting tests may require manual restart of the detection cycle.

## TEST SWITCH INDICATOR STATUS

LED Indicators Status	EM Driver Status	Method
1 Red ON 1 times /5	Battery abnormal	Check that the switch at one end of the housing is on or replace battery
2 Red ON 3 times /5	PCB abnormal	Hold for 10s to reset/reboot or replace driver
3 Red ON 3S /6S	Output power abnormal	Verify dimming wire connection Confirm lighting load ≤ rated power (see form) Check AC/ DC wiring integrity
4 Red ON 0.25/6S	Lack of electricity, recharges automatically for MAX 2 hours	Wait for the battery to fully charge first, observe for up to 6 hours, and it will switch to another mode.
5 None. LEDs OFF	Power cut, Detection and emergency mode	Check the black and white AC wires of the emergency driver, or enter the emergency mode.
6 Red ON 5.8S/6S	On charge	Normal
7 Always Red ON	Battery Fully Charge	Normal
8 Luminaire OFF	Wiring Problem	Check that the black and white AC wires of the luminaire are connected to the orange and blue wires of the emergency driver, and ensure that the brown wire of the emergency driver is connected to the switch L and the white wire is connected to N.

## JOIN CONNECTOR & APPLY POWER

- After installation is completed, join the LED emergency driver's connector and apply AC power.
- At this point, power should be connected to both the AC driver and the LED emergency driver. The charging indicator light should be illuminated indicating the battery is charging.
- At short-term discharge test may be conducted after the LED emergency driver has been charging for 2 hours. Please charge for 24 hours before conducting a long term discharge test. Refer to operation.