

DESCRIPTION

The SFP Back-lit Panels are commercial luminaires that utilizes advanced driver technology to provide an all in one luminaire, providing 3 wattages and 3 CCT options in each size panel. This provides superior lighting performance while minimizing inventory by reducing the amount of stocking SKUs. They achieve high uniformity, DLC PREMIUM energy efficiency and reduced glare in typical T-bar grid ceiling applications.

Our state-of-the-art backlit LED technology utilizes PMMA lensing over the LEDs which will not discolor over time. The need for a light guide is eliminated, thus increasing photometric performance while keeping costs competitive. Combined with the rigid back enclosure that prevents warping in application, this luminaire is designed for worry-free longevity and reliability. Available with factory installed battery backup for 90 minutes emergency egress illumination.

Project:	Date
Type:	
Model:	

SPECIFICATIONS

Construction

- Steel die-formed back-cover & frame, screw-less.

Optics

- PMMA lens over LEDs, PS diffuser
- Prismatic Lens, Low URG (17-19)
- 120° Beam angle
- 3CCT Selectable 3500K/4000K/5000K

Electrical

- 0-10VDC Dimming (5%-100%)

Certifications

- UL Listed for Damp Locations
- IC Rated for insulated ceilings
- RoHS, FCC
- DLC PREMIUM
- -5°F to 120°F

Warranty

- 5 Years

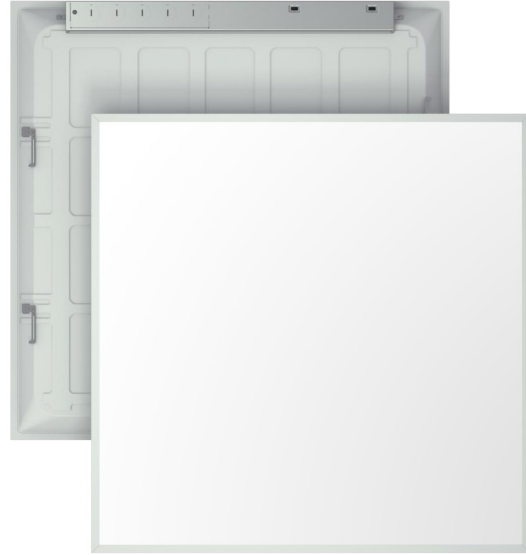

ORDER INFORMATION

EXAMPLE: SFP24-WS50-Y-CCTS



Series	Wattage Selectable	Voltage	CCT	Emergency Battery Backup
SFP22 2x2	WS40 Wattage Selectable (20 / 30 / 40)	Y 120-277V	CCTS Color Temperature Selectable (3500K / 4000K / 5000K)	(Blank) w/o Battery Backup
SFP24 2x4	WS50 Wattage Selectable (30 / 40 / 50)			EB Emergency Battery Backup (90 minutes of illumination when AC power is removed)
SFP14 1x4	WS40 Wattage Selectable (20 / 30 / 40)			

Enter configuration:

Dimensions and values shown are nominal. LuminosoLED continually works to improve products and reserves the right to make changes which may alter the performance or appearance of products.

SFP Series / Frame-less Panels

1x4, 2x4, 2x2 / Wattage & CCT Selectable



PERFORMANCE DATA

Series	SFP22 (2x2) & SFP14 (1x4)			SFP24 (2x4)		
Wattage	20	30	40	30	40	50
CCT	3500K	4000K	5000K	3500K	4000K	5000K
Lumens	2,500	3,750	5,000	3,750	5,000	6,250
Efficacy (LPW)	125			125		
CRI	80					
Input Voltage	120-277VAC 50/60Hz					
Certifications	UL Listed, FCC, RoHS					
Operating Temp.	-5°F to 120°F					
PF / THD	>0.9, <20%					
Dimming	0-10V (5%-100%)					

DIMENSIONS

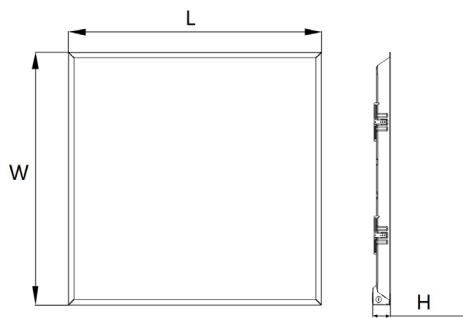

Size (FT)	LxWxH
2x2	23.74"x23.74"x1.65"
1x4	47.76"x11.93"x1.65"
2x4	47.76"x23.74"x1.65"

PHOTOMETRICS

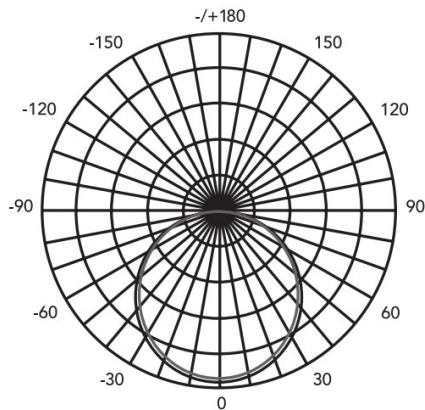

AVERAGE BEAM ANGLE (50%) : 114.3 DEG

