

GLX Series 150W LED Area Light

PRODUCT DESCRIPTION

The Luminoso GLX series combines modern styling with the latest LED technology. It is available in a wide variety of wattages ranging from 60 to 300 watts and either 4000K or 5000K. The versatile lumen packages make this product ideal for nearly any exterior lighting application. With up to 70% energy savings over its traditional counterparts the GLX presents the future of area lighting.

PERFORMANCE SUMMARY

Efficacy: 115 Lm/W
Delivered Light Output: 17,388 Lumens
Input Power: 150 Watts
CRI: Ra>80
CCT: 4000K / 5000K
Input Voltage: 120-277 / 347- 480 VAC**
Power Factor: >0.95 (120V)
Frequency: 50/60Hz
Standard Warranty: 5 Years
Standard Lifetime: Designed to L70 minimum 50,000 hours
Mounting: Slip Fitter / Direct Pole Mount / Tenon Mount
IP Rating: IP65 / Wet Rated
Die-cast aluminum housing
National listing lab tested with IES standards
Dimmable: 0-10V Dimming Capabilities
7 Pin Nema Receptacle



Slip fitter

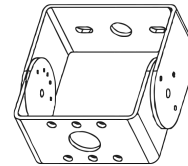

Trunion

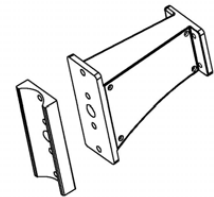

Arm

ORDER INFORMATION

EXAMPLE: GLX-150W-Y-40K-3M-22-SV



Series	Wattage	Voltage	CCT	Optics	Mount	Finish	Control
GLX	150W	Y=120-277V HV=347-480V**	30K = 3000K 40K = 4000K 50K = 5000K	2M** 3M 4M 5M	16=Slip fitter 21=Arm** 22=Trunion**	BZ = Bronze WH = White** SV = Silver**	Blank = Shorting Cap PC = 120-277V Photocell

Enter configuration:

** Special Order / contact vendor

Series / Performance

Series No.	GLX-150W		
Power	150W	LED Brightness Decay	<5%/6000 hrs
Input Voltage	AC120-277V 60Hz	Working Life	>50,000 hrs
PF	>0.95	Working Temperature	-22°F ~ 113°F
Driver Efficiency	>90%	Storage Temperature	-40°F ~ 176°F
Luminous Flux	17,388 Lm	Weight	13.2 lb
Color Temperature	3000K/4000K/5000K	IK	IK09
CRI	Ra>80	EPA	0.48-0.59 sq.ft
Lighting Angle	Type II, Type III, Type Vs	Cable	3 core, 18AWG

** Special Order

** 347-480V AC Available

Dimensions

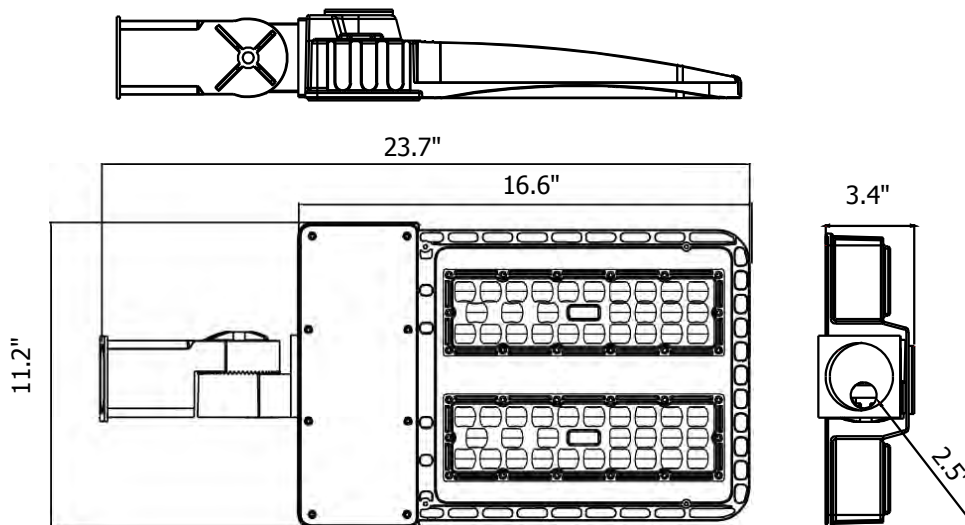

Mounting Options & Dimensions: Slip fitter / Trunnion Mount / Arm

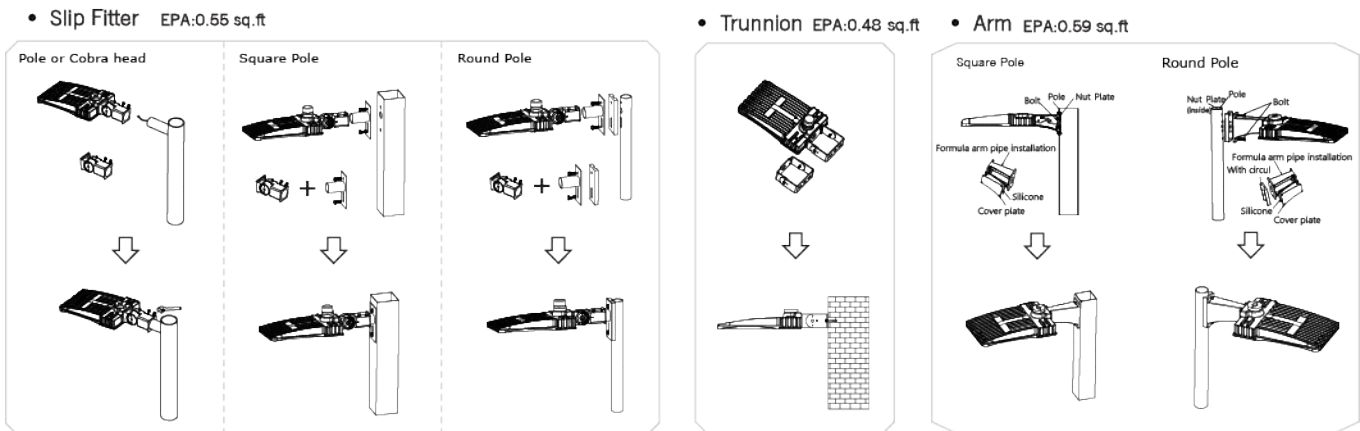

Photometry - All published luminaire photometric testing performed to IESNA LM-79-08 standards by a NVLAP accredited laboratory.

• Type II

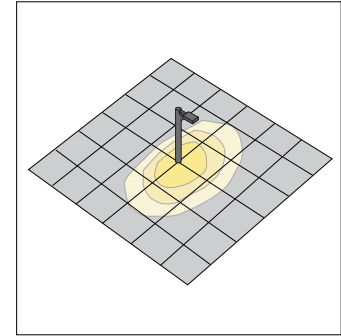
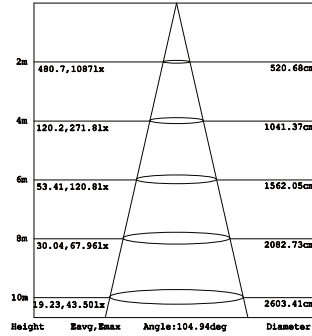
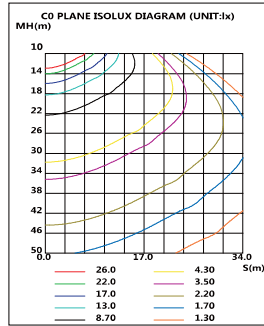
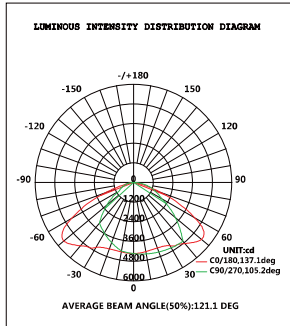

• Type III

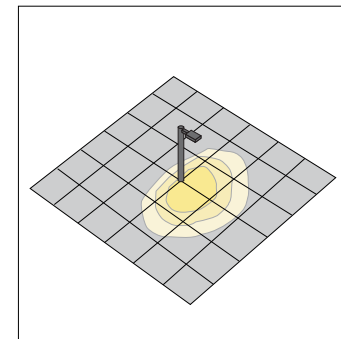
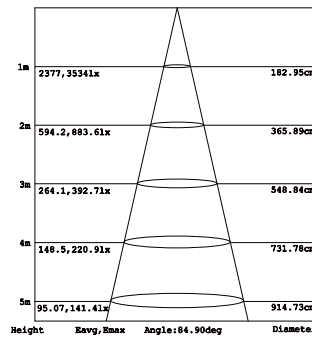
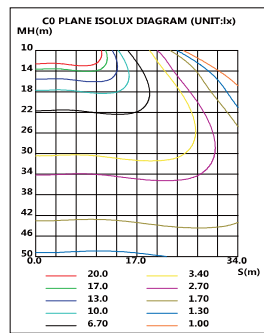
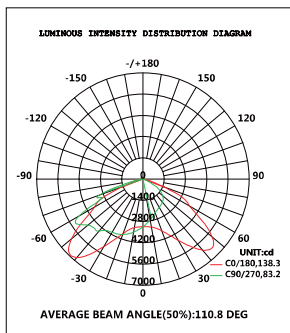

• Type V

