

## DESCRIPTION

The NHB Series high bay light is crafted with a sleek housing designed to prevent the build-up of substances such as food debris and dust, making it the top choice for demanding ambient lighting conditions. This luminaire is NSF-certified and boasts IP66 and IP69K ratings, ensuring resilience against rigorous food processing and high-pressure washing environments. With efficiency reaching up to 146 lumens per watt, it delivers impressive brightness up to 38,000 lumens. It also supports integrated sensors and emergency functionalities. The NHB Series is perfect for applications in food processing and food-safe settings, including poultry processing, food and beverage processing, commercial kitchens, and manufacturing facilities.

## FEATURES

### Construction

- The streamlined housing design allows easy cleaning and prevents the build-up of any liquid or particles.
- Integral heat sink to optimize thermal transfer and maximize performance of the LEDs.
- White finish is standard for FSF certification.

### Optics

- Achieves efficiency levels of up to **146lm/W**
- Replaces 400W and 700W MH with 150W and 200W.
- Offers standard 3000K, 4000K and 5000K light modules.
- >80 CRI
- Provides even light intensity with a 120-degree lens.

### Electrical

- Universal voltage of 120-277VAC or 480VAC (50/60Hz)
- 0-10V dimming standard for a dimming range of 100% to 10%.
- Functions in temperatures ranging from -40°C (-40°F) to 50°C (122°F)

### Controls

- Optional Microwave sensor or PIR sensor.\*

### Lifespan

- Estimated 90,000-hour LED lifespan based on IES LM-80 results and TM-21 calculations.

Project:	Date
Type:	
Model:	



## DIMENSIONS

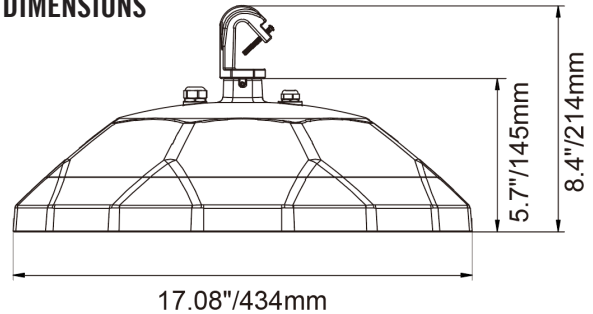

## ORDER INFORMATION

EXAMPLE: NHB-150W-Y-40K-WH



Series	Wattag	Voltage	CCT	Motion Sensor	Finish	Safety Chain	Emergency Battery Backup
NHB NSF High Bay light	150W 200W	Y 120-277V	30K 3000K	(Blank) Standard no sensor	WH White	(Blank) Standard	(Blank) Standard
		HV 480V	40K 4000K	MS PIR Motion Sensor		SC Safety Chain	EB Emergency Battery Back-up
			50K 5000K				

Enter configuration: \_\_\_\_\_

Dimensions and values shown are nominal. LuminosoLED continually works to improve products and reserves the right to make changes which may alter the performance or appearance of products.

# NHB High Bay Light

NSF Certified Food Safety Light



## PERFORMANCE DATA

Series	NHB Series	
Wattage	150	200
CCT	3000K / 4000K / 5000K	3000K / 4000K / 5000K
Lumens	21,000 / 21,300 / 21,900	28,000 / 28,400 / 29,200
Efficacy (LPW)	140 / 142 / 146	
Beam	110°	
Input Voltage	120-277VAC 50/60Hz	
Certifications	UL Listed, FCC, RoHS	
Operating Temp.	-13°F to 115°F	
PF / THD	>0.9, <20%	
Dimming	0-10V (10%-100%)	

## ELECTRICAL DATA

Series	Wattage	Current (A)		
		Input Voltage (V)		
		120V	277V	480V
NHB-150W	150	1.39	0.60	0.35
NHB-200W	200	1.85	0.80	0.46

## CONSTRUCTION

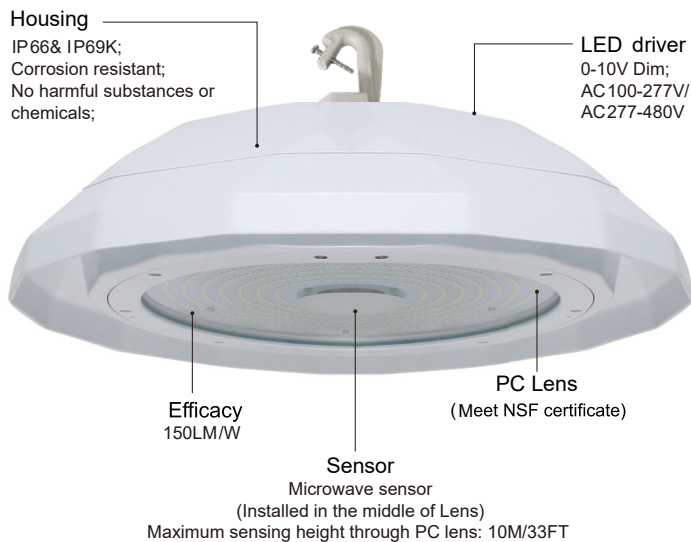

## SAFETY CHAIN (Sold separately)

