

Project:	Date
Type:	
Model:	

SHB Series High Bay

Wattage & CCT Selectable

PRODUCT DESCRIPTION

The SHB High Bay Light stands out for its impressive versatility, featuring a built-in Wattage and Color Temperature Selectable (CCT) switch. This functionality enables it to adapt seamlessly to various environments. With selectable wattage options of 240W, 200W, and 150W, as well as 150W, 120W, and 80W, it offers flexibility in power consumption. Users can also choose between color temperatures of 3000K, 4000K, and 5000K, allowing businesses and establishments to customize their lighting to meet specific needs with precision.

FEATURES

- CCT & Wattage Selectable
- Efficacy up to 160lm/W, designed to replace 450W and 750W HID.
- Die-cast aluminum housing, and polycarbonate diffuser.
- 110 degree lens guarantees light intensity and light uniformity.
- 90° optic reflector.
- Eye bolt & hook included.
- Optional motion sensor can be offered for maximizing energy savings, and security.
- IP65 Rated
- IK08 Rated
- Operating temperature is -20°F to 122°F.
- Power Factor: >0.9



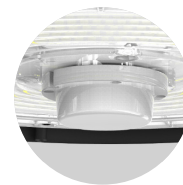

Motion Sensor Option Available



ORDER INFORMATION

EXAMPLE: SHB-WS240-Y-CCTS-AL-MS



Series	Wattage Selectable	Voltage	CCT Selectable	Reflector	Mounting	Motion Sensor
SHB High Bay	WS150 (150W / 120W / 80W)	Y Y = 120-277V	CCTS Selectable Color Temperature (3000K / 4000K / 5000K)	Blank No Reflector	Blank Eye bolt / Hook Mount	Blank No Sensor
	PC Polycarbonate Reflector 90° 			TR Trunnion 	MS PIR Motion Sensor IP65 rated / 12Vdc 	

Enter configuration: _____

Dimensions and values shown are nominal. LuminosoLED continually works to improve products and reserves the right to make changes which may alter the performance or appearance of products.

PERFORMANCE DATA

Model	SHB-WS150	SHB-WS240
System Power	150W / 120W / 80W	240W / 200W / 150W
Voltage	120-277VAC / 120-347VAV	
Frequency	50/60Hz	
Lumen (Max, 5000K)	21,125lm 17,874lm 13,260lm	38,400lm 32,000lm 24,000lm
Efficacy	160 lm/W	
Diffuser	Polycarbonate	
Body materials	Cast Aluminum	
Finish	Black	
LED type	2835	
CCT Selectable	3000K / 4000K / 5000K	
CRI	80	
PF	>0.9	
Beam angel	120°	
IP	IP65	
IK	IK08	
Installation	Hook / Trunnion	
Operating Temp.	-20°F to 122°F	
Certificate	UL	
Net Weight (lbs)	4.18	5.51

DIMENSIONS

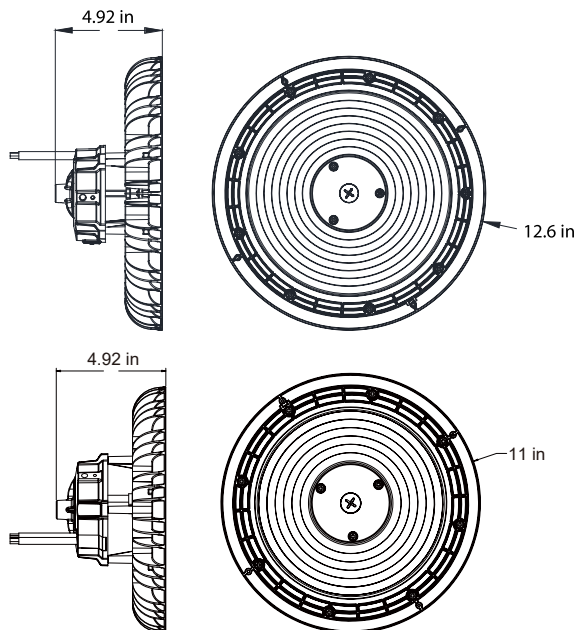

ACCESSORIES



90° PC Reflector
(Sold separately)



Hook
304 stainless steel
(Included)



50° adjustable Trunnion
(Sold separately)