

Project		Date
Type		
Model		

## EBS Series CCT/WATT Selectable

1x4 / 2x4 / 2x2 Backlit Panel

Our Dual Selectable Backlit Panels are commercial luminaires that utilizes advanced driver technology to provide an all in one luminaire, providing 3 wattages and 3 CCT options in each size panel. This provides superior lighting performance while minimizing inventory by reducing the amount of stocking SKUs. They achieve high uniformity, DLC PREMIUM energy efficiency and reduced glare in typical T-bar grid ceiling applications.

Our state-of-the-art backlit LED technology utilizes PMMA lensing over the LEDs which will not discolor over time. The need for a light guide is eliminated, thus increasing photometric performance while keeping costs competitive. Combined with the rigid back enclosure that prevents warping in application, this luminaire is designed for worry-free longevity and reliability. Available with factory installed battery backup for 90 minutes emergency egress illumination.

### SPECIFICATIONS

#### Construction

- Aluminum frame in white finish, steel die-formed back enclosure

#### Optics

- PMMA lenses over LEDs, PS diffuser
- SDCM < 5
- UGR < 22
- 120° Beam angle

#### Electrical

- 0-10VDC Dimming (10%-100%)

#### Certifications

- UL Listed for Damp Locations
- DLC PREMIUM
- IC Rated for insulated ceilings
- 4°F to 95°F
- RoHS, FCC

#### Warranty

- 5 Years

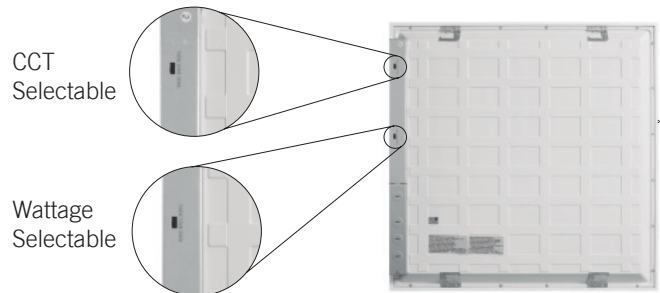

### ORDER INFORMATION

EXAMPLE: EBS22-WT-Y-CT



Series	Wattage	Voltage	CCT	Emergency Battery Backup
<b>EBS22</b> 2x2 Panel	<b>WT</b> Selectable Wattage	<b>Y</b> 120-277V	<b>CT</b> Color Temperature Selectable (3500K/4000K/5000K)	<b>(Blank)</b> w/o Battery Backup
<b>EBS24</b> 2x4 Panel				<b>EB</b> Emergency Battery Backup (90 minutes of illumination when AC power is removed)
<b>EBS14</b> 1x4 Panel				

Enter configuration:

\*\* Special Order

**PERFORMANCE DATA**

Size	EBS24 (2x4)			EBS22 (2x2)			EBS24 (1x4)		
Wattage	30	40	45	20	30	36	20	30	40
CCT	3500K/4000K/5000K			3500K/4000K/5000K			3500K/4000K/5000K		
Lumens	3750/3825/3825	5000/5100/5100	5625/5738/5738	2500/2550/2550	3750/3825/3825	4500/4590/4590	2500/2550/2550	3750/3825/3825	5000/5100/5100
Efficacy (LPW)	125-127.5			125-127.5			125-127.5		
CRI	80								
Input Voltage	120-277VAC, 0-10VDC Dimming								
Certifications	DLC PREMIUM, UL, Damp Location, FCC, RoHS								
Operating Temp	-20°C to 35°C (-4°F to 95°F)								
Warranty	5 Years								

**DIMENSIONS**

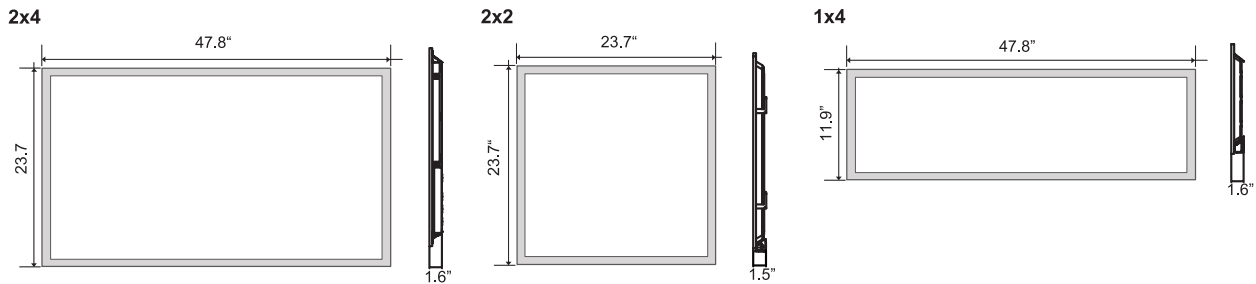

**PHOTOMETRICS**

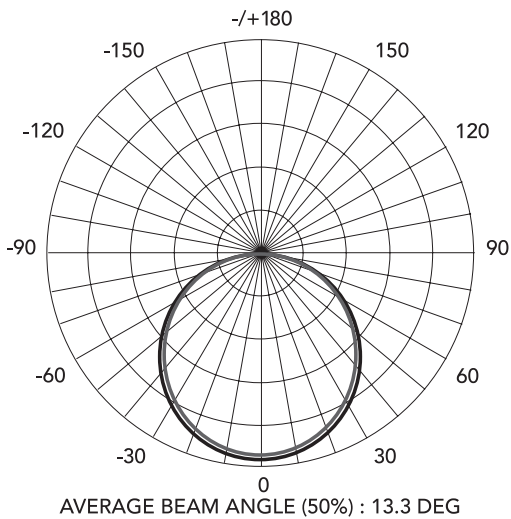

**INSTALLATION**

- Recessed in T-bar grid ceiling with integral earthquake clips for secure attachment.
- Surface mount and suspension mount cable kit accessories available.

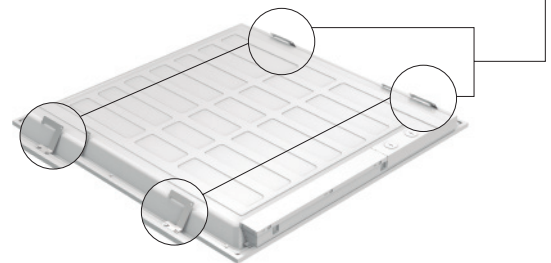

**SURFACE MOUNT KITS**

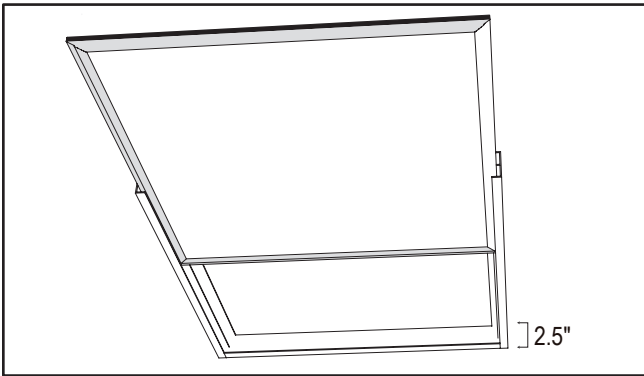

- EBS-SM-14-W 1x4 Surface Mount Kit, White
- EBS-SM-22-W 2x2 Surface Mount Kit, White
- EBS-SM-24-W 2x4 Surface Mount Kit, White

**SUSPENSION CABLE MOUNT KITS**

(Max. Adjustment Range: 3.9 Feet; Min. Adjustment Range: 0.6 Feet)

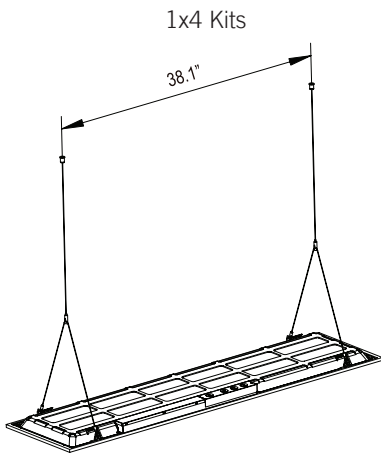

EBS-SCM-12-S 2-Cable Kit

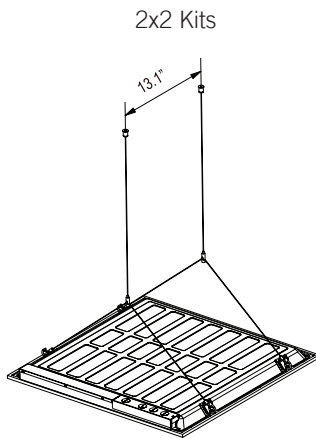

EBS-SCM-12-S 2-Cable Kit

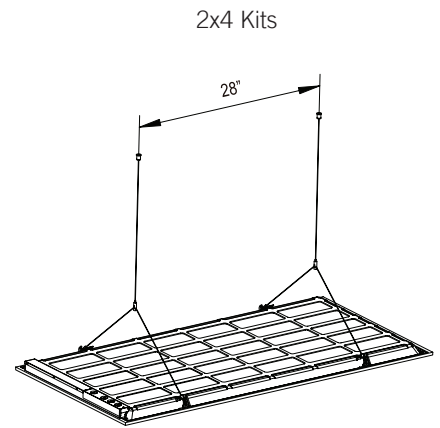

EBS-SCM-12-S 2-Cable Kit

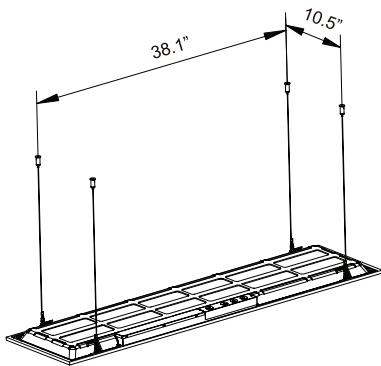

EBS-SCM-14-S 4-Cable Kit

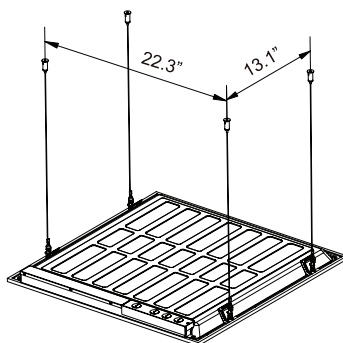

EBS-SCM-14-S 4-Cable Kit

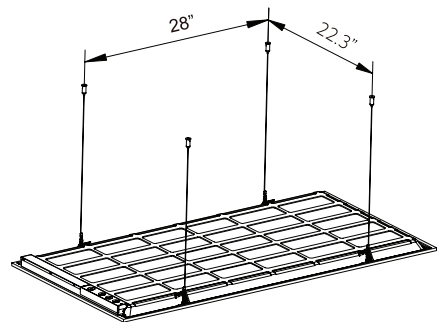

EBS-SCM-14-S 4-Cable Kit